

SHOW PRO INDUSTRIES

P.O. Box 1235, Springtown, TX 76082 / (817)523-4055 / (817)220-5117 fax
email: showpro@flash.net / www.procutter.com

Show Pro Industries would like to thank you for purchasing a Pro Cutter. Every effort has been taken to provide you with a quality product designed to provide years of trouble-free service.

Pro Cutter 1502 with Performance Package Upgrade

Packing List:

- control box (steel box containing electronic components)
- digital remote control w Stepper Technology
- off-side pulley
- installation instructions

Cow Model:

- FLEX cow*
- slide tubes w/snaps
- kevlar cable (custom cut) & "tech" line

Flag Model:

- flat braid rope (400')
- trainer flag
- (4) heavy duty cable ties for mounting control box

Note: A black & white banner can be added that will interchange with cow.

INSTALLATION INSTRUCTIONS:

Cow Model:

1. Mount control box: Securely attach control box on one side of arena. It should be mounted so pulleys on bottom of box are approximately 45 inches from the ground.
2. Mount return pulley: Mount off-side return pulley on opposite side of arena in horizontal position. It should also be mounted approximately 45 inches from the ground.
3. Install kevlar cable: Have an assistant hold cable in the center of arena. Locate the cable end **NOT** tied to slide tube. As assistant feeds off line, move towards off-side pulley, around pulley, through free sliding single snap slide tube, to control box, around pulley on bottom of control box, then back to center. Remove as much slack as possible and tie off to end of double snap slide tube. Keep in mind that the objective is to form a loop with the cable. The slide tube with two snaps supports the cow's head, and the tube with one snap supports the cow's shoulder.
4. Install "TECH" line: The tech line is static and supports the cow's hip. Tie one end of rope to fence 2-3 inches "behind" drive pulley on bottom of control box. After removing slack, tie to fence on opposite side of arena 2-3 inches behind off-side pulley. By installing tech line close to shoulder line causes the cow to travel flat, stop flat, and turn around smoothly.
5. Apply power: Plug Pro Cutter into grounded 120VAC, 3-prong outlet. Always unplug unit when not in use. **EURO MODELS:
240VAC/50Hz*
6. Attach cow: Following the included drawing, attach cow to slide tubes on kevlar cable and tech line.
7. Power on Remote: A power button is located on the right side of the remote control pouch. The power indicator light does NOT illuminate when power is ON. It only illuminates when you press the directional switches on the remote control or the Stepper switches. (Refer to Performance Package instructions on pg 9.)

OVERHEAD VIEW - COW MODEL

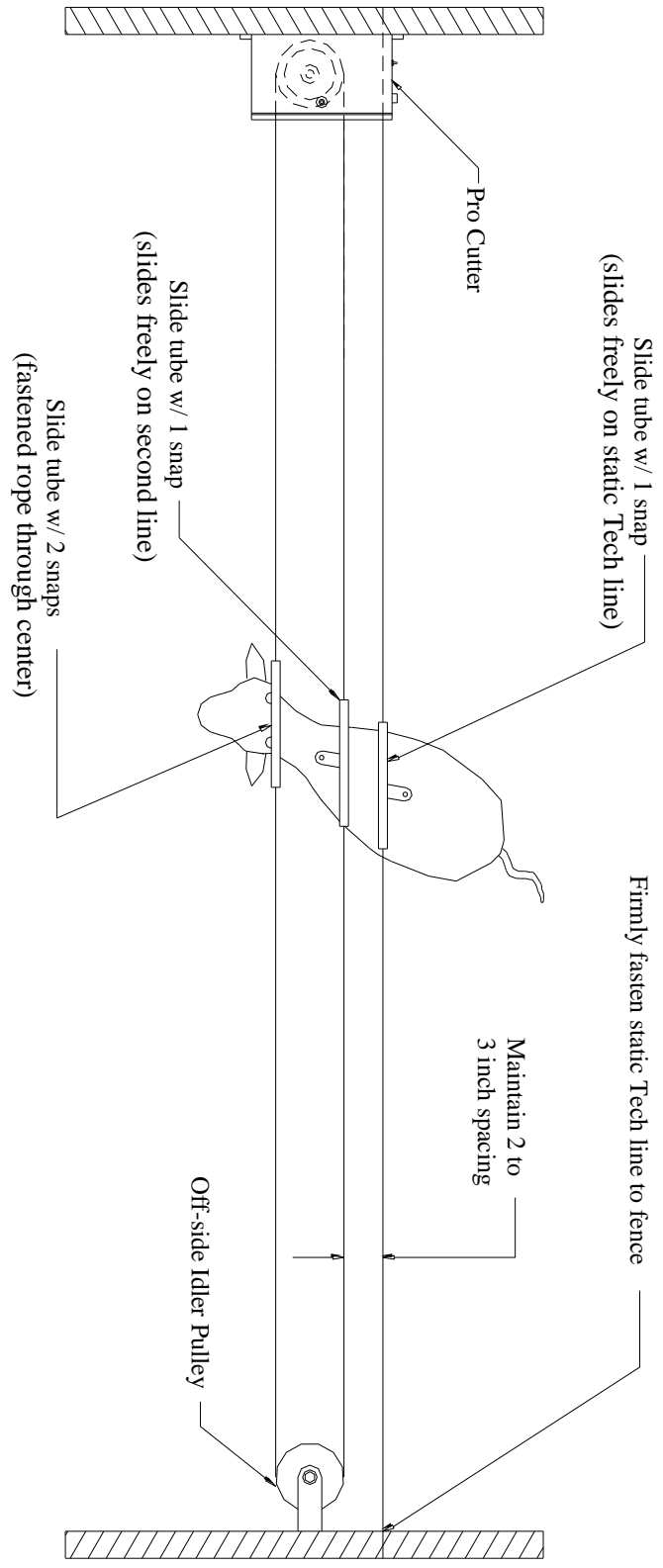

INSTALLATION INSTRUCTIONS:

Flag Model:

1. Mount control box: Securely attach control box on one side of arena. It should be mounted so pulleys on bottom of box are approximately 45 inches from the ground.
2. Mount return pulley: Mount off-side return pulley on opposite side of arena in horizontal position. It should also be mounted approximately 45 inches from the ground. The pulley will hang slack until flat braid rope is installed.
3. Install flat-braid rope: To install flat braid rope, start in center of arena. Take one end of rope around off-side pulley, across arena, around pulley on bottom of control box, and back to center. Tie one end of rope to left side of flag and other end to right side of flag while removing slack. Cut extra line.
4. Apply power: Plug Pro Cutter into grounded 120VAC, 3-prong outlet. Always unplug unit when not in use. **EURO MODELS: 240VAC/50Hz*
5. Power on Remote: A power button is located on the right side of the remote control pouch. The power indicator light does NOT illuminate when power is ON. It only illuminates when you press the directional switches on the remote control or the Stepper switches.
(Refer to the Performance Package instructions on page 9.)

FRONT VIEW - FLAG MODEL

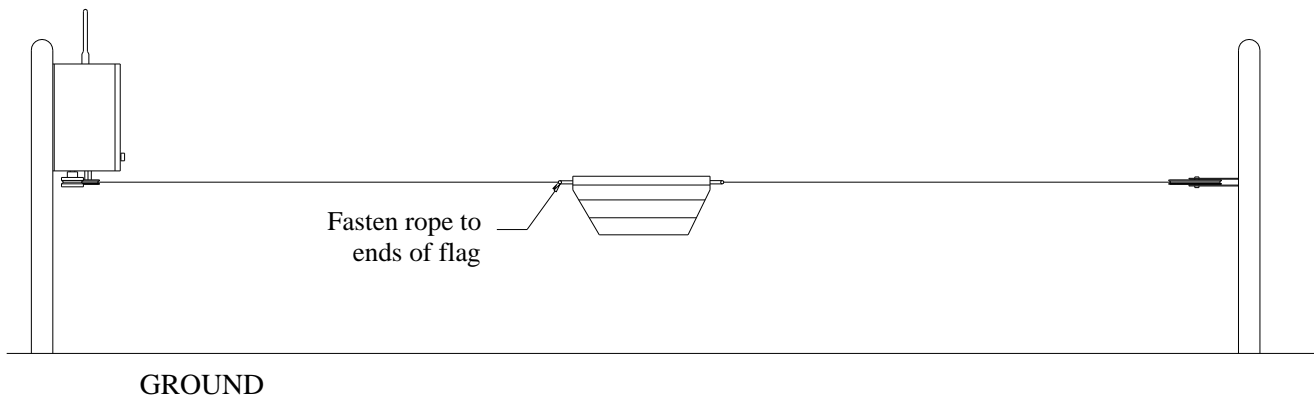

OVERHEAD VIEW - FLAG MODEL

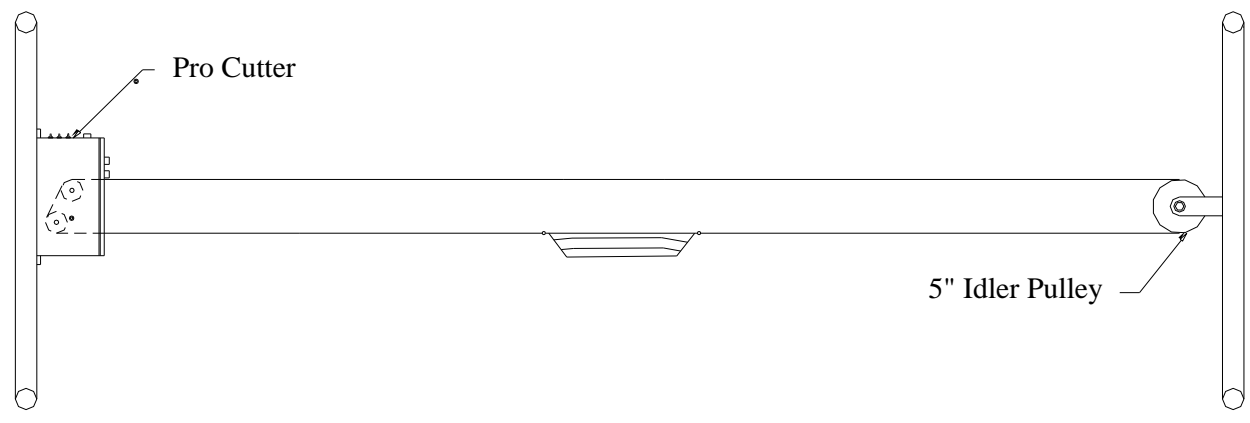

HOLE LOCATIONS FOR MOUNTING PC009 TO FIXED PANEL

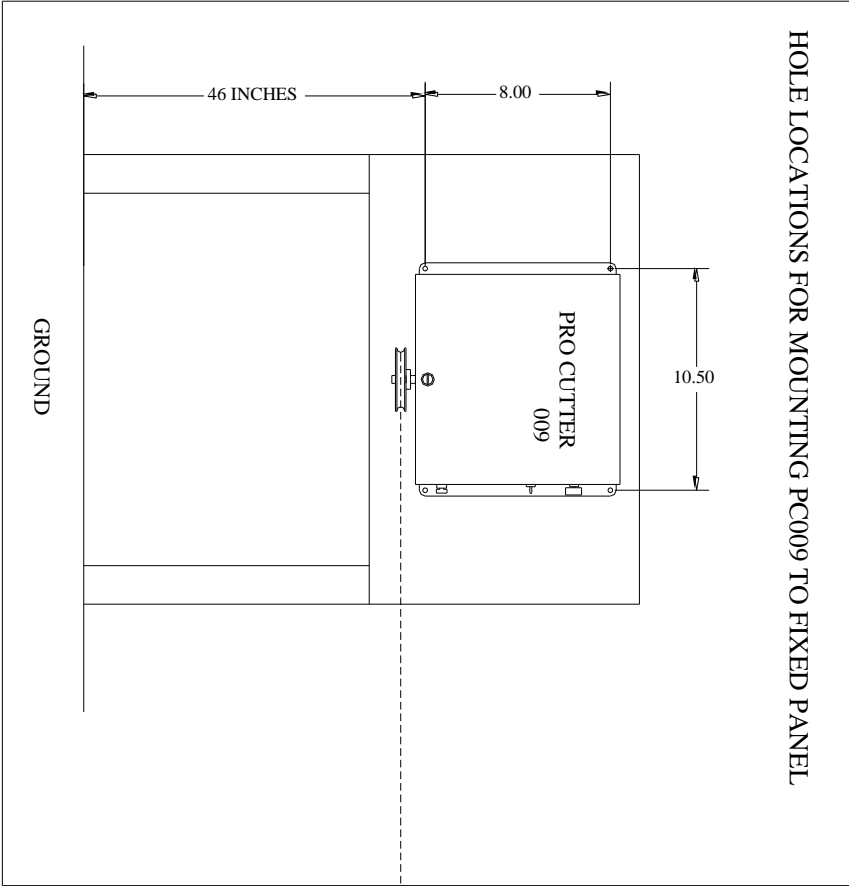

OPPOSITE SIDE OF ARENA

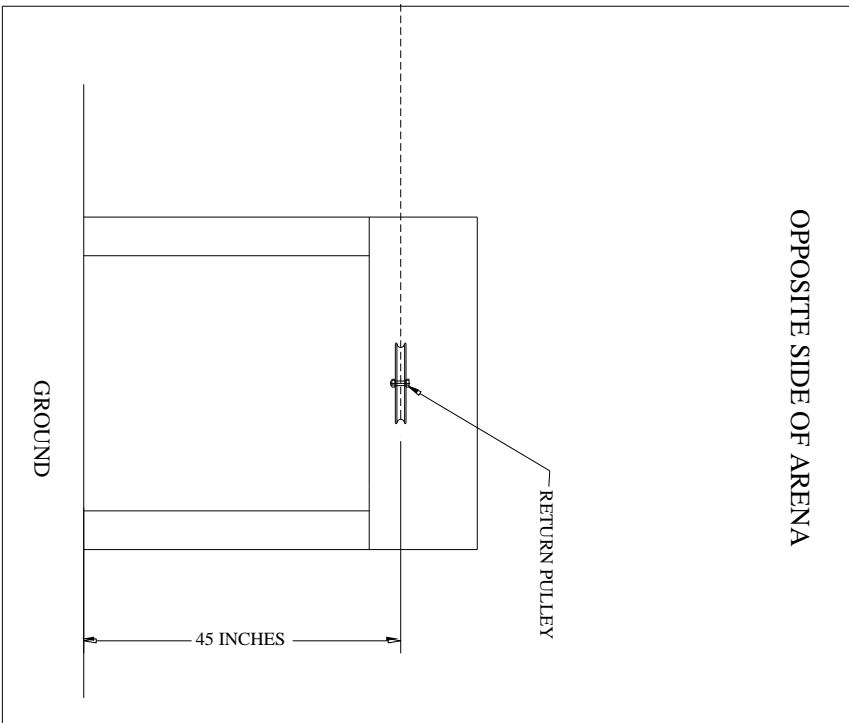

Operating Instructions:

Following is a brief description of the various switches and dials:

1. **POWER:** Flip POWER switch ON to energize control box. Red POWER light will illuminate. The unit requires 5 seconds to initialize. Avoid pressing any control buttons while unit initializes.
2. **MANUAL:** Operate control box left, right, and change speeds.
3. **LOGIC:** Switch reverses the direction that the cow or flag travels.

Example: After the Pro Cutter is installed, attach remote control to your wrist (wrist watch position) and button assembly on index finger. Press left switch with your thumb. If cow or flag travels to left, you're ready to go. However, if cow or flag travels right toggle LOGIC switch. This will cause the cow or flag to travel left as you press left switch – and right as you press right switch.

4. **FUSE:** Power surges, faulty cord, or defective component may cause a fuse to blow. When this happens, remove fuse and replace using only 4 amp/250v AGC fuse, or permanent damage may result.

NOTE: power indicator light will not illuminate when fuse is bad.

5. **SPEED DIALS: Front face of control box**

- **SPEED 1:** The left speed dial is the starting speed. When the control box is asked to run using either remote or manual control switches, the cow or flag will begin moving at Speed 1 regardless of direction. To stop, simply release button or switch.
- **SPEED 2:** The right speed dial is second speed. To access Speed 2, begin by pressing a run button on remote or manual control. The cow or flag will begin moving at Speed 1. When traveling at Speed 1, release button and re-press immediately. Control box will shift to Speed 2.

EXAMPLE: Set Speed 1 (left dial) to "15", and Speed 2 to "45". When a run button is pressed, the cow or flag will move at SPEED 1. To shift to SPEED 2, start the cow moving at

SPEED 1, then release and instantly re-press run button. The cow or flag will now travel at SPEED 2.

NOTE: When you stop, the unit automatically resets to SPEED 1.

NOTE: If the unit fails to shift to SPEED 2, double-click was not fast enough. User only has 100 milliseconds to cause speed change.

- 6. REMOTE CONTROL:** The remote control can be worn in a variety of ways depending on comfort and convenience. The most common method is to strap the control pouch to your preferred wrist, and strap the button assembly to your index (pointer) finger. The riders thumb is then used to operate the run buttons.
- 7. PRACTICE:** Attach remote control to your wrist by inserting your hand through Velcro loop on pouch. Attach switch plate to index finger and rotate buttons so they can be pushed by your thumb. Walk to center of arena and practice operating machine. Make any necessary adjustments. Once comfortable with the controls, you are ready to introduce your horse to the Pro Cutter. We recommend working at slow speeds until both horse and rider are acclimated.

ADDITIONAL FEATURES:

- * Soft-start acceleration: Progressive acceleration ramp
- * Superior radio system: Better range, less interference.
- * Large drive system: Heavy-duty industrial components
- * Weather-tight NEMA enclosure
- *Dynamic braking

Thank you for choosing.....

SHOW PRO INDUSTRIES

P.O. Box 1235, Springtown, TX 76082 / (817)523-4055 / (817)220-5117 fax
email: showpro@flash.net / www.procutter.com

PERFORMANCE PACKAGE SYSTEM UPGRADE

Your Pro Cutter is now equipped with the all new Performance Package. This full system upgrade enhances your training experience by giving the rider the ability to make speed adjustments from horseback using STEPPER technology, and an ultra-high performance remote control radio package. This new “state of the art” operator interface provides many advantages over other remote control systems. These include user programmable functions, instant response, extended range, reduced power consumption, and a flush mount antenna system.

STEPPER TECHNOLOGY:

Stepper Technology refers to the process of changing speeds from horseback using the wrist mounted remote control. After setting your base speeds on the Pro Cutter control



box, the rider can then adjust speed(s) by pressing the SPEED UP or SPEED DOWN buttons located top of the remote control pouch. Each press of either button will result in a 10% STEP in speed; with a total number of 10 STEPS available. Cycling power on the Pro Cutter control box will reset the STEPPER back to center: (-5 steps) center (+5steps)

REMOTE CONTROL:

The remote control includes an easily replaceable 9 volt battery and is ready to operate once your Pro Cutter is installed. As with any electronic device, the remote control should be stored in a cool, dry location to enhance battery life and prevent corrosion. Should the remote control become wet, damage may be prevented by immediately removing the battery and leaving the battery door off in a warm, low humidity location for several hours. The battery should also be removed during extended storage periods exceeding 2 to 3 months. Direct replacement remote controls are readily available should the original unit become lost or damaged.

A power button is located on the right side of the remote control pouch. The power indicator light does **NOT** illuminate when power is ON. It only illuminates when you press the directional switches on the remote control or the Stepper switches. Battery requires replacement if light is on continuously, or does not illuminate when control buttons are pressed. **ALWAYS** turn power button OFF when not in use.

PAIRING (PROGRAMMING):

At times it is desirable to operate multiple Pro Cutters in close proximity without the remote controls cross-communicating. This requires a simple PAIRING procedure to shift the radio package to an alternate frequency. The following procedure outlines the pairing (programming) process which requires opening the Pro Cutter drive box **with power applied**. Care must be taken to avoid contact with live circuits or electric shock may occur. Show Pro Industries accepts no responsibility for damage or injury resulting from contact with live electrical circuits. **PROGRAM RADIOS AT YOUR OWN RISK.**

- 1) Begin by opening the lid on the Pro Cutter drive box. This is accomplished using a blade screw driver on the ¼ turn lid latch. Once open, the radio receiver is located in the top-center of the control box (drawing 1). Using drawing 1 as a guide, identify the black PAIR button located near the center of the receiver circuit board.

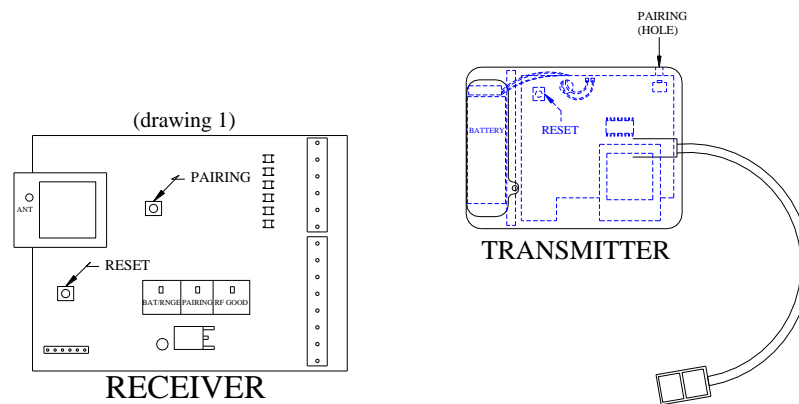

- 2) Remove the wireless remote control from the canvas/Velcro pouch. Using drawing 2 as a guide locate the pairing hole in the upper left corner of the remote control case. A small pin will be required to access the pairing switch.
- 3) With power applied to the Pro Cutter drive box, press and release the black PAIR button on the radio receiver board. A yellow PAIR indicator will illuminate on the receiver board indicating the receiver is searching for the remote control. Next, press and release the PAIR button on the remote control using a small pin. You should now see the yellow PAIR indicator flash and the green RF GOOD indicator illuminate. Wait for both indicators to turn off before pressing any buttons or switches.

Pairing is complete once both indicators turn off. Test for proper operation by pressing the remote control RUN buttons. The green RF GOOD indicator should illuminate each time a RUN button is pressed. Close Pro Cutter lid being careful to fully engage lid latch to prevent possible damage from water/dirt entering control box. Reinstall remote control case into Velcro pouch.

Important Safeguards:

1. Electrical enclosure (control box) should be protected with a non-metal roof or shield. This not only protects the paint finish but also keeps rubber components (gasket, boots, antenna, etc.) from drying out.
2. **Warning:** Electric shock or malfunction could occur if power cord or plug is damaged in any way. Do not work Pro Cutter in rain – or allow cord or plug to lie in water.
3. Always use properly grounded 120VAC electrical outlet.
4. Do not operate Pro Cutter if control box, or any of its components are damaged in any way, or after malfunction.
5. Use Pro Cutter only as intended and described in literature.
6. Always unplug Pro Cutter when through working each day.
7. Do not allow flag to run into ends, or damage may occur to electronics, rope, or both.

TROUBLE SHOOTING

Problem:

1. Pro Cutter will not operate using remote control or manual switch.

Solution:

Make sure there is power to machine. Check 4A fuse.

-
2. Pro Cutter will operate using manual switch but not remote control.

Check battery in remote control. Be sure antenna & receptacle aren't damaged.

-
3. There's a "clicking" noise but Pro Cutter won't run.

Fuse is blown.
replace fuse (4 amp, 250 v., fast blow).

NOTE: The remote control, worn on the rider's wrist, has a 9-volt battery in the plastic case inside the pouch. The battery must be changed on a regular basis.

LIMITED WARRANTY

The following warranty is in lieu of all other warranties, expressed, implied or statutory, including but not limited to any implied warranty of merchantability or fitness for a particular purpose.

All new products sold by Show Pro Industries are warranted against defects in material and workmanship for two (2) years from the date of original purchase. During the warranty period, Show Pro Industries will repair, or at its option replace without charge, any SPI product (excluding normal wear items), providing it is returned to the factory, shipping prepaid, and is proven to be defective during the subsequent factory inspection. The warranty period for products repaired after expiration of new product warranty, as stated above, is limited to the repair portion and is valid for 90 days from date of reshipment to customer. All warranties, expressed or implied, are void if product is damaged by accident, misuse or modification in the absence of written authority from Show Pro Industries.

SHOW PRO INDUSTRIES

P.O. Box 1235, Springtown, TX 76082 / (817)523-4055 / (817)220-5117 fax
email: showpro@flash.net / www.procutter.com